



SJIII 4626 | SJIII 4632 **DC ELECTRIC SCISSOR LIFTS**



Skyjack's SJIII 4626 and SJIII 4632 DC Electric Scissor Lifts offer high capacity and large platform areas, making them suitable for any on-slab application. Featuring variable speed rear wheel hydraulic drive, the Conventional Series offers working heights up to 11.75 m and 25% gradeability. A standard 0.91 m roll out extension deck can be secured in multiple positions, and both models can be driven at full height.

SKYJACK™

DC ELECTRIC SCISSOR LIFTS

SPECIFICATIONS

SJIII 4626

SJIII 4632

AS/NZS 1418.10:2011

A Work Height	9.92 m	11.75 m
B Raised Platform Height	7.92 m	9.75 m
C Lowered Platform Height	1.14 m	1.23 m
D Overall Width	1.17 m	1.17 m
E Overall Length	2.31 m	2.31 m
F Stowed Height (Rails Up)	2.15 m	2.24 m
G Stowed Height (Rails Down)	1.79 m	1.88 m
H Platform Width (Inside Dimension)	1.07 m	1.07 m
I Platform Length (Inside Dimension)	2.13 m	2.13 m
Extension Deck (Roll Out)	0.91 m	0.91 m
Ground Clearance (Stowed)	8.89 cm	8.89 cm
Ground Clearance (raised)	1.91 cm	1.91 cm
Wheelbase	1.75 m	1.75 m
Weight	2935 kg	2935 kg
Gradeability	25%	25%
Turning Radius (Inside)	1.21 m	1.21 m
Turning Radius (Outside)	2.37 m	2.37 m
Lift Time (With Rated Load)	54 sec	59 sec
Drive Speed (Stowed)	2.4 km/h	2.4 km/h
Drive Speed (Raised)	1.1 km/h	1.1 km/h
Maximum Drive Height	Full Height	Full Height
Capacity (Overall)	318 kg	318 kg
Maximum # of Persons (0 wind rating)	2	2
Maximum # of Persons (12.5 m/sec wind rating)	2	1

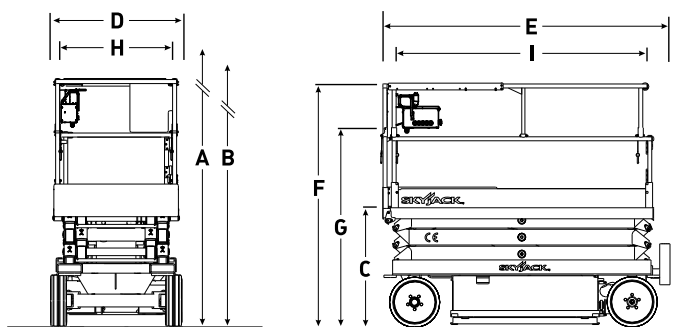

STANDARD FEATURES

- Drivable at full height
- Variable speed, rear two wheel hydraulic drive
- Wet disc SAHR brakes
- Proportional controls for drive & lift functions
- 0.91 m roll out extension deck
- 24V DC power source
- Low voltage battery protection
- 25% gradeability
- Solid rubber, non-marking tyres
- Pothole protection system
- Wiring for AC outlet on platform
- Tilt alarm with drive & lift cut-out
- All motion audible alarm
- Overload sensing system
- Lowering warning system
- Lanyard attachment points
- Operator horn
- Half height spring hinged gate
- Hinged railing system
- Forklift pockets and tie down/lift lugs
- Analog control system
- Colour coded and numbered wiring system

OPTIONS†

- Flashing light
- Dual flashing lights
- Shop airline to platform
- 250 Ah batteries
- Full height spring hinged gate

† Capacities, and machine weights may differ when options are added

Skyjack Australia Pty Ltd
 4 Coates Place
 Wetherill Park
 New South Wales, 2164
 Tel: +61 (0) 2878 63200
 Fax: +61 (0) 2878 63222
 Email: jcranmer@skyjack.com

www.skyjack.com



SKYJACK™

This brochure is for illustrative purpose only and based on the latest information at the time of printing. Skyjack Inc. reserves the right to make changes at any time, without notice, to specifications, standard and optional equipment. Consult the Operating Maintenance and Parts Manuals for proper procedures. AS marked platforms are in conformance to Standard AS/NZS 1418.10:2011.

AU/NZ/04/2013